

Bili7x™

PROFESSIONAL MANUAL



REF 1045220



+H 9061045220

RESPIRONICS®
Children's
Medical
Ventures™
Manufactured for

1001 Murry Ridge Lane
Murrysville, PA 15668
www.respironics.com

EC REP

Respironics Deutschland
Gewerbestr. 17
82211 Herrsching, Germany



1044672
HM 3/26/08

Table of Contents

1. Overview	3
Intended Use	3
What is the BiliTx Phototherapy System?.....	3
Components of the BiliTx System.....	4
2. Warnings, Cautions, and Symbols.....	5
Warnings.....	5
Cautions	7
Symbols.....	8
3. Setup	9
Checking out the System.....	9
Setting Up the BiliTx System.....	9
For Use with a Fiber Optic Panel.....	9
Setup - Wrap-Around Panel	10
Setup - Flat Neonatal Panel.....	11
For Use as Overhead Phototherapy	13
4. Cleaning and Maintenance	17
Cleaning the Illuminator Device and Fiber Optic Panel.....	17
Maintenance Schedule.....	18
Customer Service Information.....	18
5. Troubleshooting	19
6. Specifications	21
Environmental	21
Physical.....	21
Illuminator	21
Fiber Optic Panel.....	21
Light Source.....	22
Minimum Irradiance Level.....	22
Wavelength.....	22

Overhead Radiometer Certification.....	23
Effective Surface Area (Overhead Phototherapy)	24
Intensity Ratio.....	24
Audible Noise.....	24
Standards Compliance.....	25
Electrical Requirements.....	25
Disposal.....	25
Appendix A: EMC Information.....	27
BiliTx Warranty.....	31

1. Overview

This chapter explains how the BiliTx Phototherapy System is used to treat infant jaundice and it lists the components of the BiliTx system.

Intended Use

The BiliTx is intended to treat hyperbilirubinemia through phototherapy. When used as overhead phototherapy treatment, the BiliTx is for hospital/institutional use only and when used with the fiber optic light panel the BiliTx is for home or hospital/institutional use.

What is the BiliTx Phototherapy System?

The BiliTx phototherapy system uses blue light emitting diodes (LEDs) to convert bilirubin to waste products that are mostly excreted through urine and stool, thus reducing the bilirubin level in the baby's blood.

The BiliTx can be used as a fiber optic phototherapy system or as an overhead phototherapy system.

When used as a fiber optic phototherapy system, the Illuminator device sends light out of the fiber optic cable to the entire area of the panel. The panel is inserted into a protective cover. This wrap is soft and comfortable and allows the therapeutic light to be emitted towards the baby. With this use of the BiliTx system, the baby can be held and fed and enjoy the healing comfort of parents while treatment is administered. Additionally, when the BiliTx system is properly used with the fiber optic panel the baby's eyes do not need to be protected as with conventional phototherapy.

When the BiliTx is used as overhead phototherapy, the Illuminator device is connected, using the overhead therapy kit, to a hospital intravenous (IV) pole and can be positioned over an incubator or radiant warmer. The unit delivers phototherapy by sending a band of blue light down onto the baby. With this method of phototherapy, the baby's eyes must be covered with appropriate eye patches, such as the WeeSpecs® Supreme phototherapy mask.

Components of the BiliTx System

The BiliTx system includes the following components. Some components are optional accessories that may not be packaged with your device.

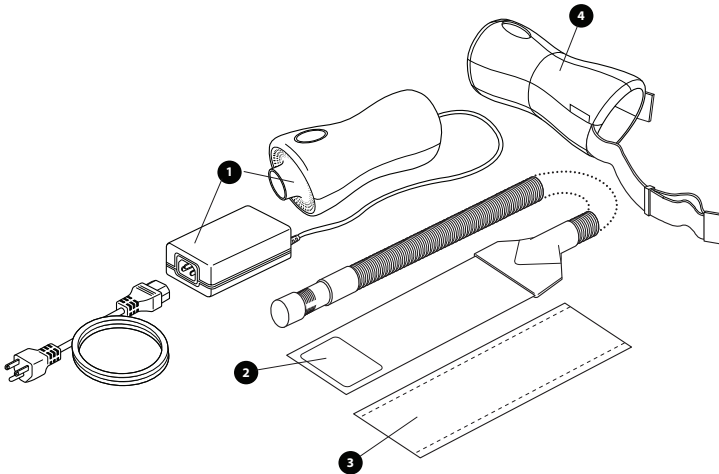

Fiber Optic Light Panel Configuration for Home or Hospital/Institutional Use

1. Illuminator Device with AC Power Cord
2. Fiber Optic Panel
3. Disposable Cover
4. Illuminator Device Carrying Case (optional)
5. System Carrying Case (optional) (not shown)
6. Tape (not shown)
7. Instruction Manual (not shown)



Fiber Optic Light Panel Configuration Contents

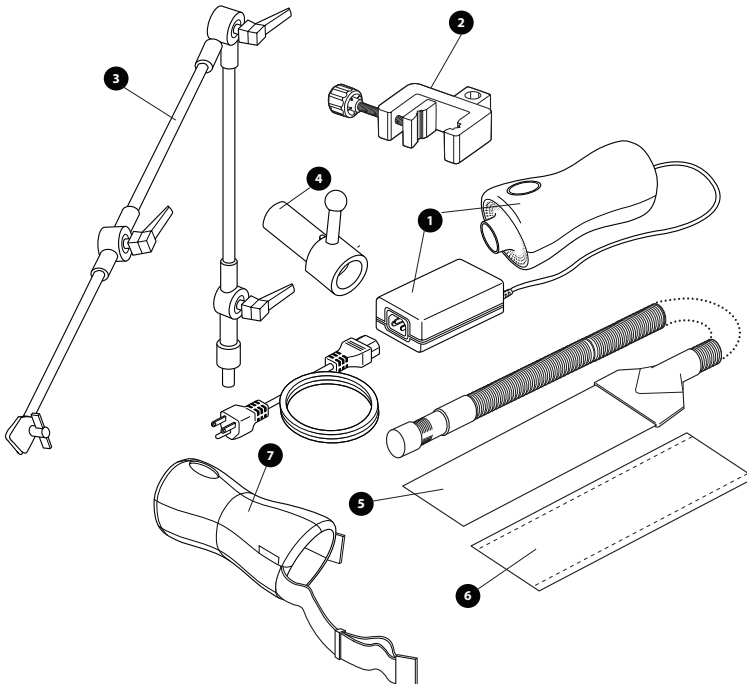

Overhead Phototherapy Configuration for Hospital/Institutional Use

1. Illuminator Device with AC Power Cord
2. Mounting Brace
3. Circuit Support Arm
4. Circuit Support Adapter
5. Fiber Optic Panel
6. Disposable Cover
7. Illuminator Device Carrying Case (optional)
8. Instruction Manual (not shown)



Overhead Phototherapy Configuration Contents

2. Warnings, Cautions, and Symbols

Caution! US federal law restricts this device to sale by or on the order of a physician.

Warnings

- Use the BiliTx only for its intended use as described in this manual.
- Eye protection is necessary if the Illuminator device will be used for overhead phototherapy or if the panel is illuminated while not attached to the baby. Normal use of the Illuminator device with the panel in a disposable cover does not require the use of eye protection.
- During overhead therapy, check the eye protection to ensure that they remain properly fitted.
- Ensure that other patients near the phototherapy equipment are not exposed to the phototherapy. Patients adjacent to overhead phototherapy treatment may need to be protected with eye protection.
- Some operators may experience mild effects (e.g., headache, nausea) if in the irradiated area for a long period of time. To minimize the effects, use the system in an area with a lot of light or use glasses with yellow lenses.
- Bilirubin photoisomers may cause toxic effects.
- Do not leave the Illuminator device on when the fiber optic panel is not around the baby.
- Always turn off and unplug the Illuminator device during cleaning or servicing.



A warning indicates the possibility of injury to the user or operator.

- Do not use the BiliTx system in the presence of flammable substances such as anesthetics, cleaning agents, or gases that support combustion (e.g. oxygen, nitrous oxide).
- Do not use while bathing the baby.
- Do not place or store the BiliTx system where it can fall or be pulled into a tub or sink.
- If the Illuminator device falls into water or if fluid is spilled on the device do not reach for it without first unplugging the cord. Discontinue use of the device and contact an authorized Respironics service center.
- Never operate the Illuminator device if it has a damaged plug or damaged or frayed power cord or wires. Do not insert anything into the end of the plug.
- Do not use an extension cord.
- Always connect the device to a properly grounded outlet.
- If therapy is interrupted for any reason, resume therapy as soon as possible.
- Carefully place the panel cable to avoid entanglement.
- Position the Illuminator device on a stable surface, preferably lower than the infant. When the BiliTx system is used with the fiber optic panel configuration and carrying case, the device can hang on the outside of a crib or treatment area.
- Do not place the Illuminator device, power supply, or carrying case in an incubator or infant warmer.
- Do not place a temperature sensor for the infant warmer or incubator under the fiber optic panel or in the surface area of the overhead phototherapy light.
- Do not place the Illuminator device, power supply, or carrying case in a crib or other treatment area next to the baby.
- Never block the air vents of the unit or place it on a soft surface such as a bed, crib, carpeted floor, or couch where the air vents may be blocked.

- During phototherapy, the the baby's water balance may become disturbed. Before and during phototherapy, make sure the baby is properly hydrated and that his or her body temperature is maintained.
- After treatment has begun, the baby's bilirubin level should be measured to make sure therapy is effective.
- Adjust therapy location and time as necessary to avoid degradation of photosensitive drugs and infusion liquids. Do not store any drugs in the illuminated area.
- The fiber optic panel must not be covered by anything except with the cover provided. Any other type of cover will cause a reduction in light intensity. The setup instructions must be followed exactly.
- Varying ambient conditions, such as the ambient temperature and/or different radiation sources, may adversely affect the patient. Please refer to your hospital phototherapy policy and procedure regarding appropriate ambient conditions.

Cautions

- Keep the unit away from any heated surface.
- Do not scratch, damage, or soil the ferrule end of the panel. Also, do not place sharp or heavy items on the panel, this can damage the panel and affect its light output.
- Do not dry the fiber optic panel with artificial heat.
- If the device is dropped, contact your an authorized service representative to inspect for proper operation.









CAUTION

A caution indicates the possibility of damage to the device.

Symbols

The following symbols appear on the BiliTx system.

Symbol	Explanation
	Therapy On/Off
	Consult accompanying instructions for use
	Type BF applied part
	AC Power
	European Declaration of Conformity
	Canadian/US Safety Certification. Conforms to ANSI/UL STD. 2601. Certified to CAN/CSA C22.2 STD. NO. 601.1.
	Eye shields required

3. Setup

Checking out the System

Prior to each patient setup, the hospital should check the light intensity of the unit. The Joey Dosimeter should be used to measure the light intensity. See the *Cleaning and Maintenance* section later in this manual for more information.

Setting Up the BiliTx System

For Use with a Fiber Optic Panel

1. Place the appropriate cover on the panel and position the baby and panel as described later in this chapter. (See Setup-Wrap Around Panel or Flat Neonatal Panel.)
2. Place the Illuminator device on a hard, flat surface or using the carrying case, hang the unit on the outside of a crib or the treatment area, away from any heat source. Make sure it is no more than four feet from where the baby will be positioned.
3. Insert the metal end of the light panel cable, called the ferrule, with the metal post facing up, into the opening on the Illuminator unit. Rotate the ferrule a ¼ turn counter-clockwise to lock into place. The light will not come on if the panel is not inserted in the Illuminator device.
4. Plug the Illuminator device into an electrical outlet. The Therapy On/Off button will flash green.

 **WARNING**

After treatment has begun, the baby's bilirubin level should be measured to make sure therapy is effective.

 **CAUTION**

Do not block any of the air vents on the Illuminator device.

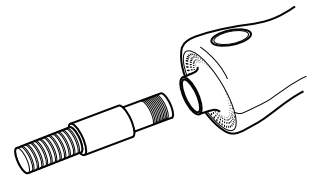

Connecting the light panel cable to the illuminator device

 **CAUTION**

If the power cord or wires need repair or replacement, do not connect the unit.

5. Press the Therapy On/Off button to turn the Illuminator device on and begin phototherapy. The Therapy button will illuminate green.

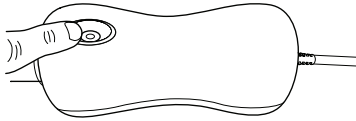

6. To turn off the device when therapy is complete, press and hold the Therapy On/Off button for 3 seconds.



Turning on the illuminator device

Setup - Wrap-Around Panel

This section explains how to prepare a baby for a phototherapy treatment using the wrap-around fiber optic light panel.

The fiber optic panel must NOT be covered by anything except with the cover provided. Any other type of cover could cause a reduction in light intensity. The setup instructions must be followed exactly.

This panel provides full coverage around the baby's torso. It is most commonly used on patients at home.

1. Place a disposable or reusable cover onto the panel with the light emitting side of the panel facing the sheer side of the cover.

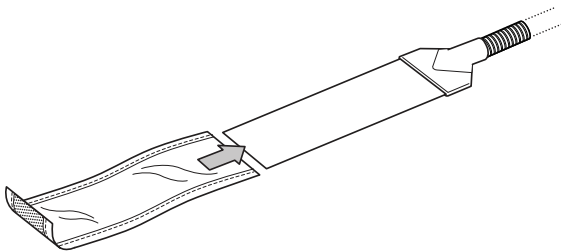

Wrap-around panel with disposable cover

2. Place the covered panel under the baby's torso, positioning it so it is under the baby's armpits.
3. Wrap the panel around the baby. Use the tape or hook and loop tabs to secure the panel around the baby.

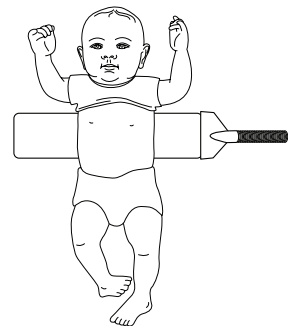

Positioning the fiber optic panel

- If the disposable cover becomes soiled, discard it and replace with a clean one. The cloth cover may be washed with mild soap and water.

NOTES

For a larger or more active baby, you may want to tape the panel to the baby's diaper.

To be sure the panel is not wrapped too tightly, insert your finger between the panel and the baby's body. Your finger should fit easily.

You may wrap the baby in a blanket or put the baby in a sleeper.

WARNING

If using tape to secure the panel, do not adhere the tape to the baby's skin.

Setup - Flat Neonatal Panel

This section explains how to prepare a baby for a phototherapy treatment using the flat neonatal fiber optic light panel.

The fiber optic panel must NOT be covered by anything except with the disposable cover provided. Any other type of cover could cause a reduction in light intensity. The setup instructions must be followed exactly.

This panel is ideal for premie or underweight infants; it may also be used on full-term infants.

- The protective cover for the neonatal panel is a T-vest. Slide the vertical section of the T, with the light facing the sheer side of the cover, onto the panel.

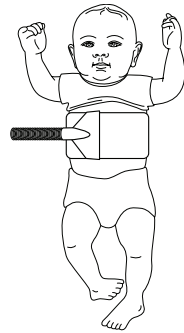
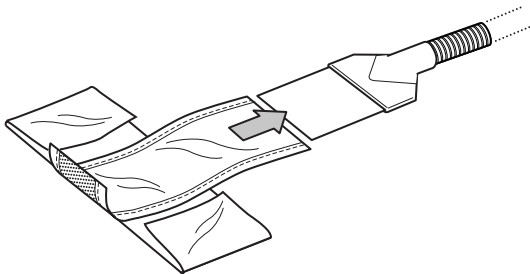

Wrapping and securing the panel



Neonatal panel with t-vest

2. Lay the covered panel on a flat surface. Be sure the light emitting side is facing up.
3. Position the baby's chest or back directly on the panel. The cable connected to the panel should be between the baby's legs.
4. Secure the T-vest to the baby by first wrapping the side without the tape around the baby's midsection. Then, wrap the side with the tape tab over the infant, peel off the protective cover on the tab, and secure it. Be sure the vest is snug.
5. If the T-vest becomes soiled, discard it and replace it with a new one.

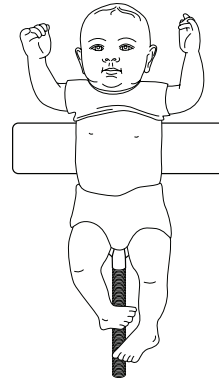

Positioning the baby on the panel

NOTES

For a larger or more active baby, you may want to tape the panel to the baby's diaper.

To be sure the panel is not wrapped too tightly, insert your finger between the panel and the baby's body. Your finger should fit easily.

You may wrap the baby in a blanket or put the baby in a sleeper.

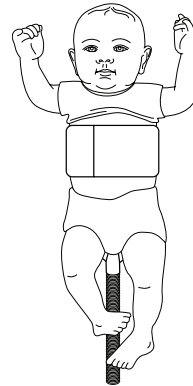

Wrapping and securing the T-vest

WARNING

If using tape to secure the panel, do not adhere the tape to the baby's skin.

For Use as Overhead Phototherapy

NOTE: Overhead phototherapy is for hospital/institutional use only.

The following section explains how to prepare the unit for overhead phototherapy treatment. Overhead phototherapy can be used while the baby is in an incubator or radiant warmer. You will need the mounting brace accessory kit to set up and position the device.

1. Attach the mounting brace to a standard hospital intravenous (IV) pole. To attach, place the clamp around the IV pole then tighten using the screw provided.

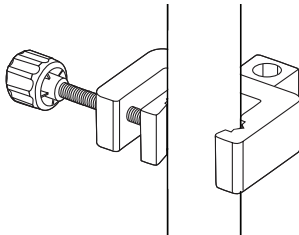

2. Connect the circuit support arm to the mounting brace. To securely attach, turn and lock the circuit support arm into place.

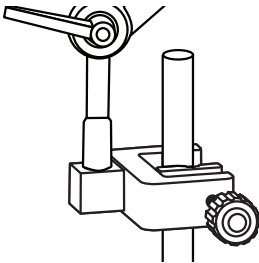

3. Insert the circuit support adapter into the opening on the Illuminator device with the metal post facing up. Turn the adapter counter-clockwise to securely lock in place.

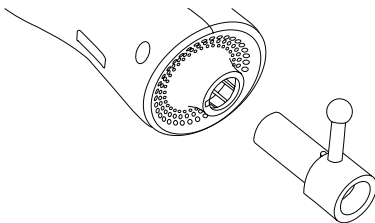

CAUTION

Do not block any of the air vents on the Illuminator unit.



Attaching the brace to an IV pole



Attaching the circuit support arm to the mounting brace



Attaching the circuit support adapter to the Illuminator device

- Connect the circuit support adapter to the clamp on the circuit support arm. Tighten in place by turning the handle on the clamp.

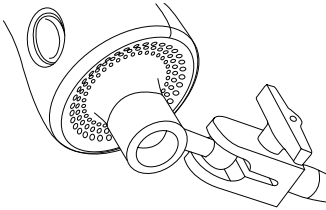

- Attach the device power cord to the circuit support arm.
- Position the device over the baby ensuring that it is no closer than 6 inches from the baby. The intensity of light can be adjusted by positioning the light source closer or farther away from the baby. See the light intensity chart in the *Specifications* chapter of this manual for the approximate light intensity at specific distances from the device.
- Cover the baby's eyes with the appropriate eye protection. Refer to the instructions included with your eye protection.
- Plug the Illuminator device into an electrical outlet. The power button will flash green.
- Press the Therapy On/Off button to turn the Illuminator device on. The Therapy button will illuminate green.

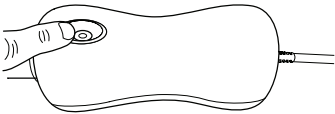

- To turn off the device when therapy is complete, press and hold the Therapy On/Off button for 3 seconds.



Connecting the circuit support adapter to the circuit support arm



WARNING

The power cord must be attached to the circuit support arm to avoid entanglement.



WARNING

Do NOT position the device closer than 6 inches from the baby.



WARNING

Verify that the Illuminator unit is securely attached to the circuit support arm and the mounting brace is securely attached to the IV pole before placing the baby under the device.



WARNING

Place the IV pole supporting the unit so that it will not be accidentally disturbed during overhead therapy.



CAUTION

If the power cord or wires need repair or replacement, do not connect the device.

The graphic below shows the complete overhead phototherapy setup.

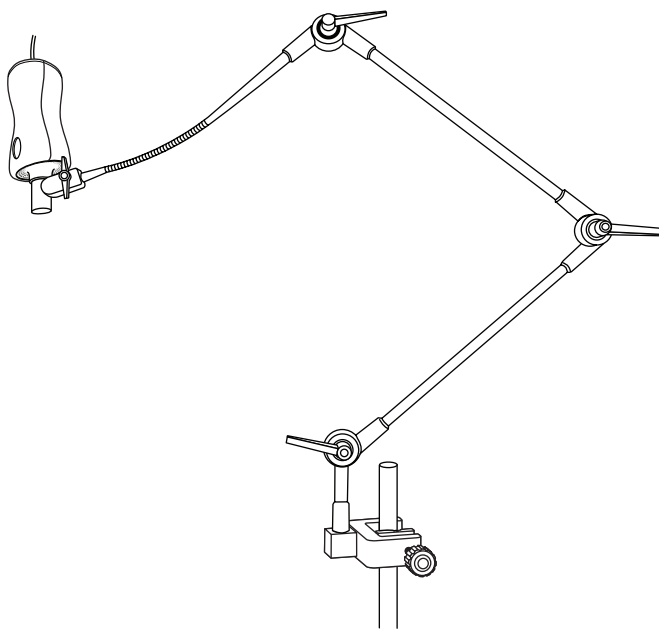

**Overhead phototherapy
complete assembly**

Using the In-Use Carrying Case

An optional, in-use carrying case is available for use with the Illuminator device. The carrying case allows for easy mobility during phototherapy treatment. To place the carrying case on the Illuminator device, simply slide it over the device and adjust the position so that the Start/Stop button is visible. The shoulder strap should be located at the same end as the power cord. You can adjust the shoulder strap as necessary using the hook and loop tabs.

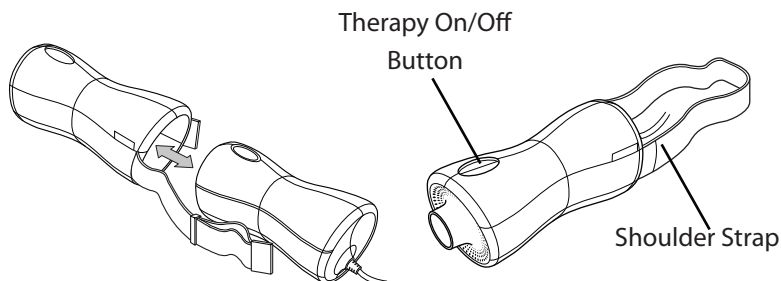

4. Cleaning and Maintenance

This section explains how to clean, check, and maintain the BiliTx system.

Cleaning the Illuminator Device and Fiber Optic Panel

Follow the instructions in this section any time the Illuminator device or fiber optic panel is dirty.

1. Use soapy water, a 10% bleach solution or full strength ammonia.
2. Use a soft sponge or cloth to apply the cleaner.
3. Apply the cleaning solution to the sponge or cloth and wipe down the fiber optic panel and Illuminator.
4. Allow the equipment to air dry. **DO NOT DRY WITH ANY MEANS OF ARTIFICIAL HEAT.**
5. Wipe the Illuminator device and panel with a dry cloth.

If the in-use carrying case becomes soiled, it can be wiped with a damp cloth.



CAUTION

Be sure the Illuminator device is turned off and is unplugged before cleaning. Do not immerse any part of the equipment in any liquid.



CAUTION

Keep the fiber optic panel away from sharp objects that could scratch or puncture the cover.



WARNING

When cleaning, DO NOT USE:

- Phenolic compound based germicide cleaner/disinfectant
- Gluteraldehyde disinfectant/sterilants
- Regular commercial cleaners or laundry detergents
- Iodine solutions, strong acids or strong alkali solutions

These solutions could leave residue on the surfaces, and /or be abrasive or harmful to the infant.

Maintenance Schedule

Follow the schedule and instructions below to keep the BiliTx system properly maintained. The light has a minimum lifetime of 30,000 hours. The number of hours your device has been used can be found in the window on the bottom of the device.

Before Each Patient Use	As Needed
Check light intensity. The Joey Dosimeter should be used to measure the light intensity. If the intensity falls below the minimum standard, contact Respirationics Customer Service.	Clean the Illuminator device and fiber optic panel.
Replace the disposable light panel cover or vest.	
Inspect the power cord and plug for damage or fraying.	
Verify light does not illuminate when panel is not inserted or connected to the IV pole.	

Customer Service Information

To contact Respirationics directly, call the Respirationics Customer Service department at 1-800-345-6443 or 1-724-387-4000.

You can also use the following address:

Respirationics
1001 Murry Ridge Lane
Murrysville, Pennsylvania
15668-8550 USA

HELPFUL TIP

Visit Respirationics web site at www.respirationics.com.

5. Troubleshooting

The following is a list of problems that may occur while using the BiliTx system. For additional information, refer to the *BiliTx Service Manual* or contact Respironics Customer Service at 1-800-345-6443 or 1-724-387-4000.



WARNING

If therapy is interrupted for one hour or longer, resume therapy as soon as possible.

Problem	Reason/Action
Therapy On/Off button is not green	Check to make sure power cord is properly attached and plugged into an active electrical outlet. Ensure the device is turned on.
Therapy On/Off button is not flashing green	If the power cord is properly attached and plugged into an active electric outlet and the Therapy On/Off button is not flashing green, but the device will turn on, continue to use the device for therapy.
Light is not being emitted from fiber optic panel	Check to make sure panel is securely locked into Illuminator device.
Yellow LED is flashing	Ensure the panel or circuit support adapter is securely locked into place. If light continues to flash, contact Respironics.
Loss of power or light source failure	Contact Respironics.
Light is not being emitted from the illuminator device when connected to the circuit support adapter and the yellow LED is flashing	Check to make sure the Illuminator device is securely attached to the circuit support adapter accessory.
Device will not turn off when the Therapy On/Off button is pressed	Press and hold the Therapy On/Off button for 3 seconds.

6. Specifications

Environmental

	Storage	Operating
Temperature	-20 to +50° C	15 to 35° C
Relative Humidity	15-95% Non-condensing	15-95% Non-condensing

Physical

Illuminator

Size: 6.34 in. x 2.92 in. (16.10 cm x 7.40 cm)

Weight: <2.50 lb. (1.13 kg)

Fiber Optic Panel

Model:	EG-2000 (Wrap Around Panel)
Overall Pad Size-Standard:	4.00" x 15.00" (10.16 cm x 38.10 cm)
Illuminated Area-Standard:	3.00" x 14.00" (7.62 cm x 35.56 cm)
Model:	EG-2000N (Flat Neonatal Panel)
Overall Pad Size-Neonatal:	5.00" x 7.00" (12.70 cm x 17.78 cm)
Illuminated Area-Neonatal:	4.00" x 6.00" (10.16 cm x 15.24 cm)

Light Source

Minimum Irradiance Level

Standard Panel-Light:	30 μ W/cm ² /nm
Neonatal Panel-Light:	55 μ W/cm ² /nm
Overhead Therapy:	When the illuminator is positioned 30 cm (12 inches) above the neonate: 30 μ W/cm ² /nm

Wavelength

Blue LEDs: Peak between 460 nm and 480 nm

The graph below shows the total spectral irradiance of the Illuminator device averaged over a wavelength range. Also included is a calibration curve of the Joey Dosimeter, which was used to take the measurements of the light.

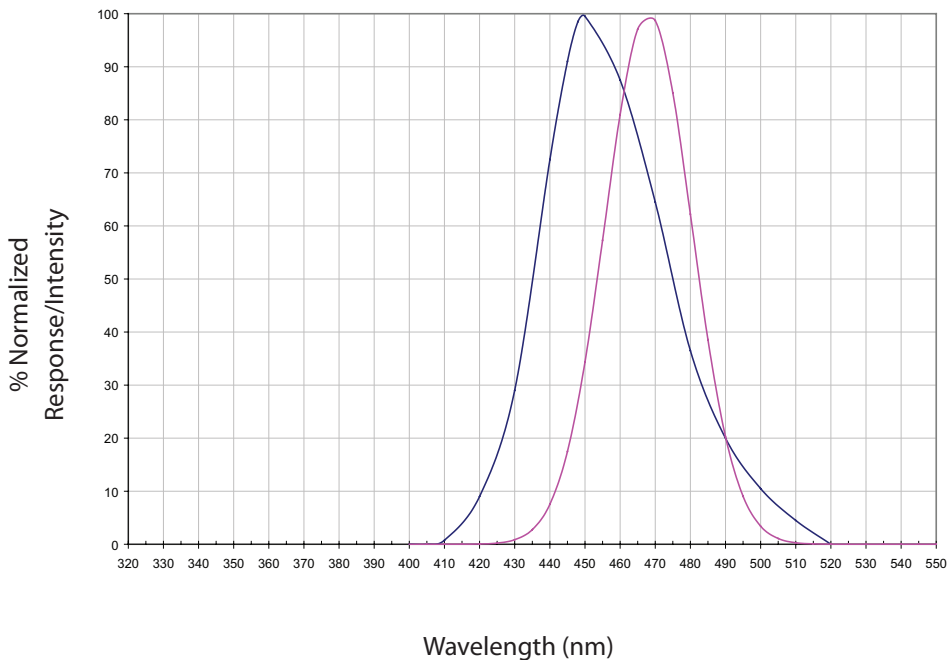

Overhead Spectral Irradiance

Total Irradiance of 94 mW/cm².

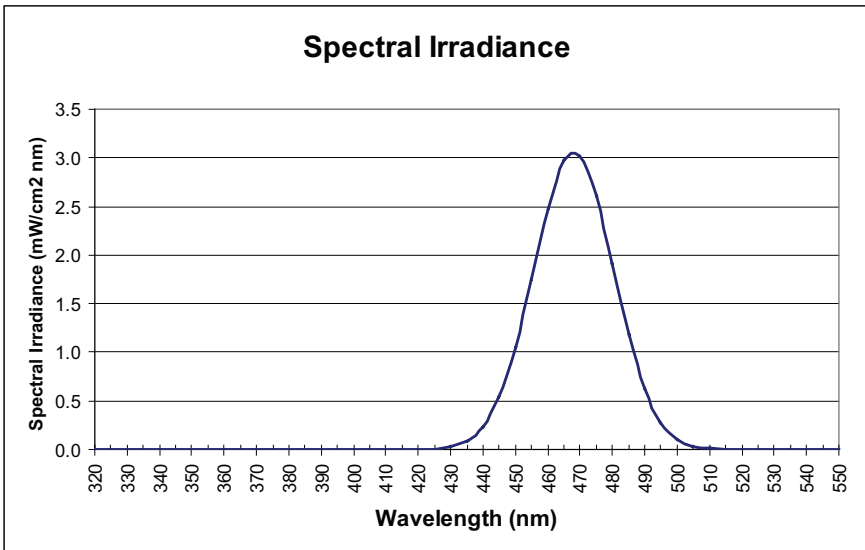

Overhead Radiometer Certification

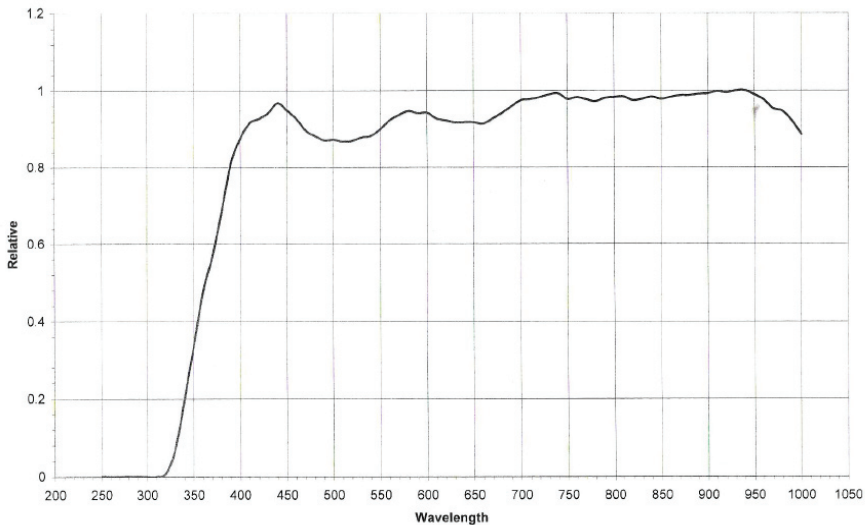

Light Intensity (Overhead Phototherapy)

Distance	Irradiance ($\mu\text{W}/\text{cm}^2/\text{nm}$)
15 cm (6 in)	112
30 cm (12 in)	30
45 cm (18 in)	16
60 cm (24 in)	9

Effective Surface Area (Overhead Phototherapy)

14 cm diameter at a height of 30 cm (12 inches)

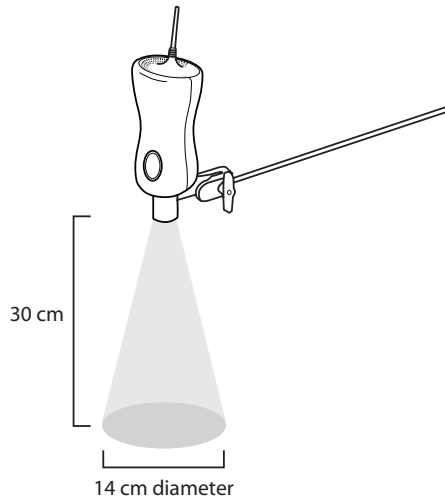

Intensity Ratio

Standard Panel, Neonatal Panel, and Overhead Phototherapy : > .4 (minimum to maximum)

Audible Noise

< 60 dB(A). Measured in accordance with IEC 60601-2-50.

Standards Compliance

This device is designed to conform to the following standards:

- IEC 60601-1 General Requirements for Safety of Medical Electrical Equipment
- IEC 60601-2-50 Requirements for the Safety of Infant Phototherapy Equipment
- Electromagnetic Compatibility: EN 60601-1-2, 2nd edition.

Electrical Requirements

AC Power	100-240 VAC, 50/60 Hz, 1.0 A
Type of Protection Against Electrical Shock	Class I Equipment
Degree of Protection Against Electrical Shock	Type BF Applied Part
Degree of Protection Against Ingress of Water	Ordinary Protection, IPX0
Mode of Operation	Continuous

Disposal

Dispose of this device in accordance with local regulations.

Appendix A: EMC Information

Guidance and Manufacturer's Declaration - Electromagnetic Emissions

This device is intended for use in the electromagnetic environment specified below. The user of this device should make sure it is used in such an environment.

Emissions Test	Compliance	Electromagnetic Environment - Guidance
RF emissions CISPR 11	Group 1	The device uses RF energy only for its internal function. Therefore, its RF emissions are very low and are not likely to cause any interference in nearby electronic equipment.
RF emissions CISPR 11	Class B	The device is suitable for use in all establishments, including domestic establishments and those directly connected to the public low-voltage power supply network.
Harmonic emissions IEC 61000-3-2	Class A	
Voltage fluctuations/Flicker emissions IEC 61000-3-3	Complies	

Guidance and Manufacturer's Declaration - Electromagnetic Immunity

This device is intended for use in the electromagnetic environment specified below. The user of this device should make sure it is used in such an environment.

Immunity Test	IEC 60601 Test Level	Compliance Level	Electromagnetic Environment - Guidance
Electrostatic Discharge (ESD) IEC 61000-4-2	±6 kV contact ±8 kV air	±6 kV contact ±8 kV air	Floors should be wood, concrete or ceramic tile. If floors are covered with synthetic material, the relative humidity should be at least 30%.
Electrical Fast Transient/Burst IEC 61000-4-4	±2 kV for power supply lines ±1 kV for input-output lines	±2 kV for supply mains ±1 kV for input/output lines	Mains power quality should be that of a typical home or hospital environment.
Surge IEC 61000-4-5	±1 kV differential mode ±2 kV common mode	±1 kV differential mode ±2 kV for common mode	Mains power quality should be that of a typical home or hospital environment.
Voltage dips, short interruptions and voltage variations on power supply input lines IEC 61000-4-11	<5% U_T (>95% dip in U_T) for 0.5 cycle 40% U_T (60% dip in U_T) for 5 cycles 70% U_T (30% dip in U_T) for 25 cycles <5% U_T (>95% dip in U_T) for 5 sec	<5% U_T (>95% dip in U_T) for 0.5 cycle 40% U_T (50% dip in U_T) for 5 cycles 70% U_T (30% dip in U_T) for 25 cycles <5% U_T (>95% dip in U_T) for 5 sec	Mains power quality should be that of a typical home or hospital environment.
Power frequency (50/60 Hz) magnetic field IEC 61000-4-8	3 A/m	3 A/m	Power frequency magnetic fields should be at levels characteristic of a typical location in a typical hospital or home environment.
NOTE: U_T is the a.c. mains voltage prior to application of the test level.			

Guidance and Manufacturer's Declaration - Electromagnetic Immunity

This device is intended for use in the electromagnetic environment specified below. The user of this device should make sure it is used in such an environment.

Immunity Test	IEC 60601 Test Level	Compliance Level	Electromagnetic Environment - Guidance
Conducted RF IEC 61000-4-6 Radiated RF IEC 61000-4-3	3 Vrms 150 kHz to 80 MHz 3 V/m 80 MHz to 2.5 GHz	3 Vrms 3 V/m	Portable and mobile RF communications equipment should be used no closer to any part of the device, including cables, than the recommended separation distance calculated from the equation applicable to the frequency of the transmitter. Recommended separation distance: $d = 1.2 \sqrt{P}$ 150 kHz to 80 MHz $d = 1.2 \sqrt{P}$ 80 MHz to 800 MHz $d = 2.3 \sqrt{P}$ 800 MHz to 2.5 GHz Where P is the maximum output power rating of the transmitter in watts (W) according to the transmitter manufacturer and d is the recommended separation distance in meters (m). Field strengths from fixed RF transmitters, as determined by an electromagnetic site survey a , should be less than the compliance level in each frequency range b . Interference may occur in the vicinity of equipment marked with the following symbol: 
<p>NOTE 1: At 80 MHz and 800 MHz, the higher frequency range applies.</p> <p>NOTE 2: These guidelines may not apply in all situations. Electromagnetic propagation is affected by absorption and reflection from structures, objects, and people.</p> <p>a: Field strengths from fixed transmitters, such as base stations for radio (cellular/cordless) telephones and land mobile radios, amateur radio, AM and FM radio broadcast and TV broadcast cannot be predicted theoretically with accuracy. To assess the electromagnetic environment due to fixed RF transmitters, an electromagnetic site survey should be considered. If the measured field strength in the location in which the device is used exceeds the applicable RF compliance level above, the device should be observed to verify normal operation. If abnormal performance is observed, additional measures may be necessary, such as re-orienting or relocating the device.</p> <p>b: Over the frequency range 150 kHz to 80 MHz, the field strengths should be less than 3 V/m.</p>			

Recommended Separation Distances between Portable and Mobile RF Communications Equipment and this Device

The device is intended for use in an electromagnetic environment in which radiated RF disturbances are controlled. The customer or the user of this device can help prevent electromagnetic interference by maintaining a minimum distance between portable and mobile RF communications equipment (transmitters) and this device as recommended below, according to the maximum output power of the communications equipment.

Rated Maximum Power Output of Transmitter (W)	Separation Distance According to Frequency of Transmitter (m)		
	150 kHz to 80 MHz $d = 1.2 \sqrt{P}$	80 MHz to 800 MHz $d = 1.2 \sqrt{P}$	800 MHz to 2.5 GHz $d = 2.3 \sqrt{P}$
0.01	0.12	0.12	0.23
0.1	0.38	0.38	0.73
1	1.2	1.2	2.3
10	3.8	3.8	7.3
100	12	12	23

For transmitters rated at a maximum output power not listed above, the recommended separation distance d in meters (m) can be estimated using the equation applicable to the frequency of the transmitter, where P is the maximum output power rating of the transmitter in watts (W) according to the transmitter manufacturer.

Note 1: At 80 MHz and 800 MHz, the separation distance for the higher frequency range applies.

Note 2: These guidelines may not apply in all situations. Electromagnetic propagation is affected by absorption and reflection from structures, objects, and people.

BiliTx Warranty

Respironics, Inc. warrants your BiliTx Phototherapy System against defects in material and workmanship of the Illuminator device and the fiber optic panels, EG-2000 and EG-2000N, for a period of one (1) year from the date of purchase. In addition, Respironics warrants the LED light engine for 20,000 hours. This warranty does not cover any damage to the illuminating device or the fiber optic panel caused by accident, misuse, tampering, or negligence such as failure to follow the instructions provided in this guide. In the event your phototherapy illumination unit fails to give satisfactory performance within the warranty period and conditions, Respironics, Inc. will repair or replace your illuminating device at no charge for parts or labor. The foregoing warranties are in lieu of all other warranties expressed or implied, including without limitation any implied warranty of merchantability or fitness for a particular purpose.

